

LBD8904/00 Desktop Handset Station

www.boschsecurity.com



BOSCH
Invented for life



- ▶ Easy-to operate.
- ▶ Two independent communication channels.
- ▶ Facility for paging and party line announcements.
- ▶ Pilfer proof station, operates smoothly in noisy, hazardous industrial environment.
- ▶ Available with unique handset receiver.

The Handset station for Industrial communication system is designed to withstand the harsh industrial environments. The handset stations are simple to operate, facilitates plant wide communication during critical situations smoothly.

System overview

The desktop handset station LBD8904 consists of fibre glass housing with a handset. This is the single electronic module which provides the necessary pre amplification and signal processing. When used with extension amplifier LBD8924, it operates as complete handset station with all the functions of a standard industrial public address system.

The three snap-action, non-locking micro switches provided on front panel give the necessary functions, like page and private channel functions along with the optional facilities. Built in priority and siren facilities can be accommodated into the electronic circuit simply with the help of jumper wire.

Functions

Call establishment

The page function with the proper placement of the speakers attached to the call station will enable any announcement to be heard all over the plant. The party line function will facilitate the conversation

of two or more people without being heard over the speakers once a call is established. The operation is simple-the user lifts the handset from the call station and press the page button, makes the announcement to a specific zone or to the entire plant, the required individual(s) lifts nearby station and the duplex communication can commence over the party line. Up to 6 individuals can participate in the conversation on each party line.

Control and Operation

Paging announcement can be made by pressing the push button switch on the front panel. Loudspeaker can be muted using the push button switch. The functional switch can be customized as per the requirement like external call indicators, priority operations etc. Volume of the speaker can be controlled from front panel through the screw-driver adjustable volume controller.

Certifications and approvals

Ingress protection Acc. to IP52

Installation/configuration notes

Dimension & Mounting Details: LBD8904/00

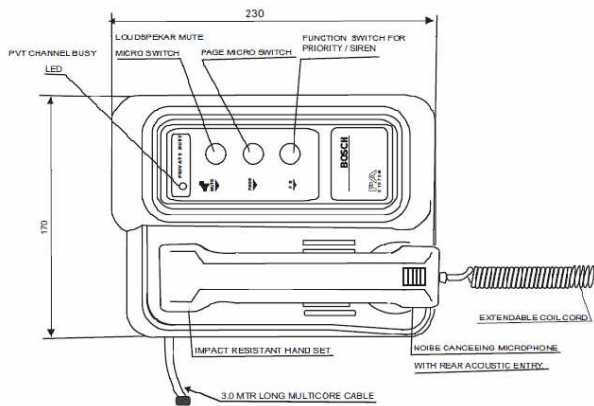
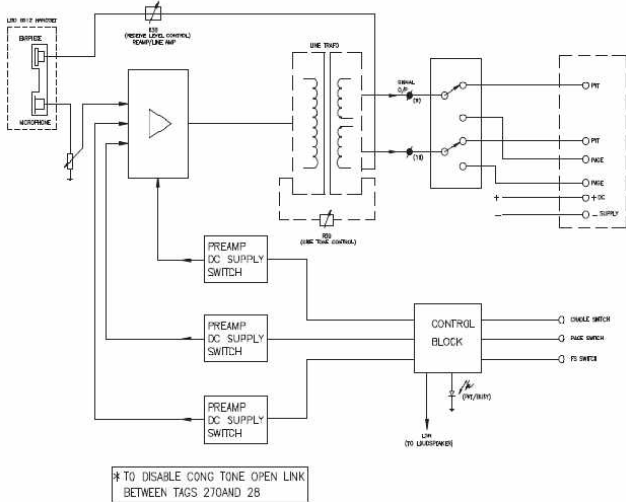

Parts included

Quantity	Components
1	Power Supply Cord
1	Triangular Screw Driver
1	2 Meter coiled cords
1	User Instructions Manual

Technical specifications

Electrical

Power Supply voltage 220VAC ± 10% 50/60Hz or 24VDC

Current consumption 150 mA at 24VDC

Microphone

Type Dynamic noise canceling

Internal impedance	230Ω±15%
Sensitivity	0.7mV/Pa
Line Receiver	
Input sensitivity	5mV adjustable by preset R1.
Rated o/p	2 Volts
Input Impedance	2kohms
O/p Impedance	2kohms
Gong tone O/p	6V(+/-1 V Peak to Peak starting amplitude)
Gong tone frequency	600 Hz (± 100 Hz)
Distortion at rated output	<1%
Gong tone frequency	600 Hz(±100 Hz)
Hum and Noise	Better than 45 dB
Side tone cancellation	Upto 15 dB below rated O/p

Mechanical

Dimension(HxWxD)mm	110x230x170
Weight	1.8 kg
Colour	Front panel - Dark Brown Rear housing - Beige

Environmental

Operating temperature	-20°Cto+55°C
Storage temperature	-40°Cto+70°C
Relative humidity	95%
Environmental protection	IP 52

Ordering information

LBD8904/00 Desktop Handset Station
Order number **LBD8904/00**

Represented by:

Americas:

Bosch Security Systems, Inc.
130 Perinton Parkway
Fairport, New York, 14450, USA
Phone: +1 800 289 0096
Fax: +1 585 223 9180
security.sales@us.bosch.com
www.boschsecurity.us

Europe, Middle East, Africa:

Bosch Security Systems B.V.
P.O. Box 80002
5617 BA Eindhoven, The Netherlands
Phone: + 31 40 2577 284
Fax: +31 40 2577 330
emea.securitysystems@bosch.com
www.boschsecurity.com

Asia-Pacific:

Robert Bosch (SEA) Pte Ltd, Security
Systems
11 Bishan Street 21
Singapore 573943
Phone: +65 6571 2808
Fax: +65 6571 2699
apr.securitysystems@bosch.com
www.boschsecurity.asia

China:

Bosch (Shanghai) Security Systems Ltd.
203 Building, No. 333 Fuquan Road
North IBP
Changning District, Shanghai
200335 China
Phone +86 21 22181111
Fax: +86 21 22182398
www.boschsecurity.com.cn

America Latina:

Robert Bosch Ltda Security Systems Division
Via Anhanguera, Km 98
CEP 13065-900
Campinas, Sao Paulo, Brazil
Phone: +55 19 2103 2860
Fax: +55 19 2103 2862
latam.boschsecurity@bosch.com
www.boschsecurity.com